

MAGNETIT SPEICHERSTEINE - Kaminöfen Storch

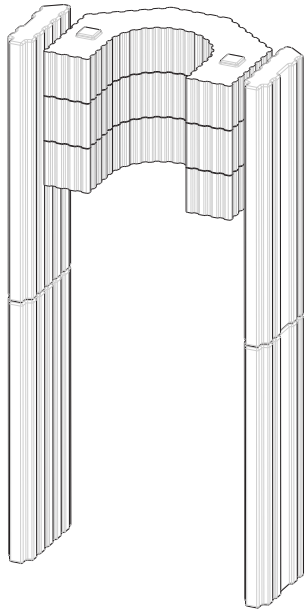

ASKJA SE / EX

75 kg

Artikel Nr.:

ASK AKKUM

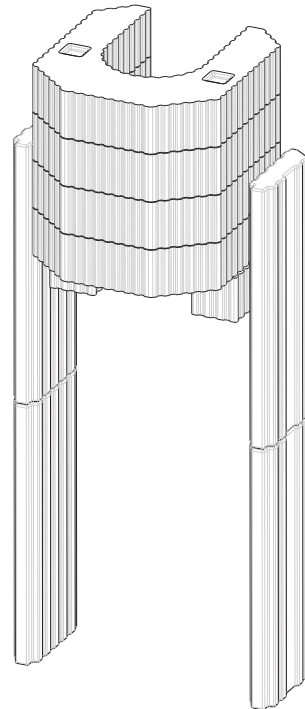

ASKJA H

127 kg

Artikel Nr.:

ASK H AKKUM

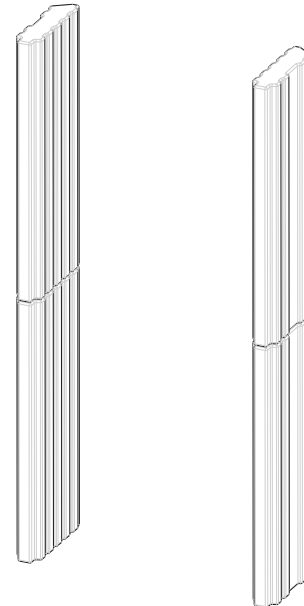

ASKJA BF

40 kg

Artikel Nr. :

ASK BF AKKUM

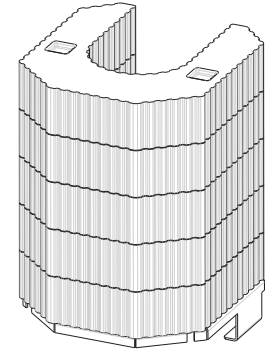

VULSINI H

96 kg

Artikel Nr.:

VUL H AKKUM

MAGNETIT SPEICHERSTEINE - Kaminöfen Storch

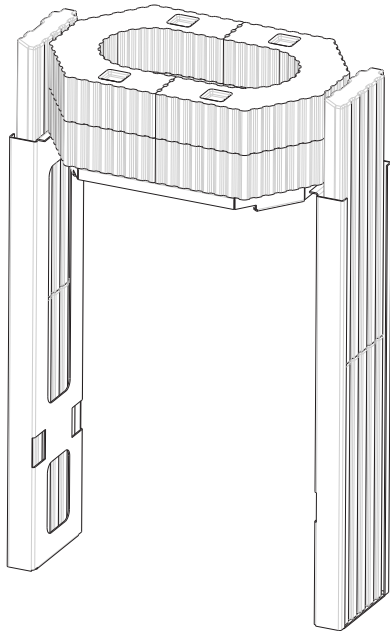

ECUADOR STAHL

93 kg

Artikel Nr.:

ECU AKKUM 01

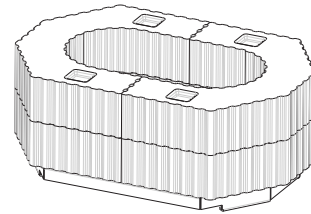

ECUADOR
KERAMIK / STEIN

48 kg

Artikel Nr.:

ECU AKKUM 02

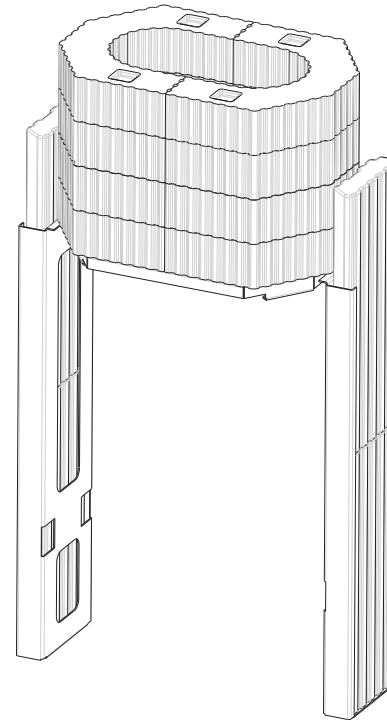

ECUADOR H
STAHL

140 kg

Artikel Nr.:

ECU H AKKUM 1

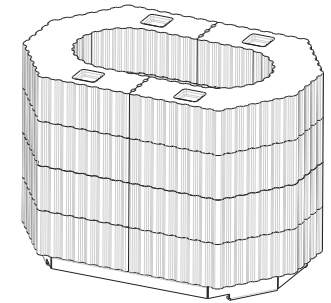

ECUADOR H
KERAMIK / STEIN

94 kg

Artikel Nr.:

ECU H AKKUM 2